

# *Design and Implementation of Intelligent Lighting Ducontrol System for Speech Recognition Based on Arduino*

Zhijie Zhao<sup>1,a</sup>, Bo Tang<sup>2,b</sup>, Tiangu Wu<sup>5,c</sup>, Weiyuan Zhang<sup>5,d</sup>, Meng Wu<sup>1,e</sup>, Zijun Zhao<sup>4,f</sup>, Wenbo Bao<sup>3,g</sup>, Mengyu Cui<sup>3,h</sup>, Qian Xiong<sup>5,i</sup>, Xiangchi Chen<sup>5,j</sup>, Wenwen Yue<sup>5,k</sup>, Deli Gao<sup>1,l</sup>

<sup>1</sup> School of aerospace engineering, Shenyang Aerospace University, Shenyang 110136, China

<sup>2</sup> Engineering Training Center, Shenyang Aerospace University, Shenyang 110136, China

<sup>3</sup> Material science and Engineering, Shenyang Aerospace University, Shenyang 110136, China

<sup>4</sup> Electronic information Engineering, Shenyang Aerospace University, Shenyang 110136, China

<sup>5</sup> School of Mechatronics Engineering Shenyang Aerospace University, Shenyang 110136, China

<sup>a</sup>33205631293@qq.com, \*Corresponding author

Email: <sup>b</sup>1092786432@qq.com, <sup>c</sup>692843533@qq.com, <sup>d</sup>2431411283@qq.com, <sup>e</sup>673636594@qq.com, <sup>f</sup>1059372593@qq.com, <sup>g</sup>970911006@qq.com, <sup>h</sup>782212110@qq.com, <sup>i</sup>1316243202@qq.com, <sup>j</sup>673869073@qq.com, <sup>k</sup>2731089086@qq.com, <sup>l</sup>2957083201@qq.com.

**Keywords:** Arduino, SCM, Intelligent lighting, Speech recognition

**Abstract:** Arduino is a hardware and software platform for the development of electronic interactive products. Based on the Arduino MCU, the speech recognition system is configured to build an intelligent lighting system to realize that the home lighting can automatically adjust the brightness of the light according to the human voice commands and adjust the light color according to the ambient temperature. In daily home life, such intelligent lighting systems can make people's lives more comfortable and can effectively achieve lighting energy saving.

## 1. Introduction

The home system with the electronic system as the core is the development trend of future smart home. This paper introduces an intelligent voice recognition intelligent lighting control system based on Arduino. The establishment of voice recognition intelligent lighting control system, hardware is the key and foundation, it has a direct impact on the stability of the entire system, control and feedback accuracy, energy saving, smart home appliances through the processing of electronic technology, to integrate or control the home electronics Electrical products make home life more comfortable, safe and effective. Compared with ordinary home appliances, smart home appliances not only have traditional home appliance functions, but they can also turn from passive passive structures to intelligent tools that actively recognize voice execution based on voice of people command, optimize people's lifestyles [1], and help people effectively arrange Time, enhance the safety and comfort of home life. At present, domestic lighting control mainly adopts traditional key control. In the case of dim lighting, it is difficult for the user to control conveniently, and collisions

often occur. Design a lighting control system based on speech recognition, which can recognize the user's voice and control the lighting according to the user's requirements. It can improve the intelligence and comfort of the user's residence and has good practicality [2].

## **2. The Need for Speech Recognition Intelligent Lighting Control System**

At present, the common lighting control system is the traditional button control system. When the user needs to turn on the lights or turn off the lights, they need to manually touch the switch buttons. Therefore, at night, when the user needs to turn on the lights, the collision often occurs. Such traditional lighting The control system is inconvenient. With the continuous improvement of living standards of residents, traditional lighting control can no longer meet the people's demand for quality of life. Intelligent control uses advanced computer technology and embedded devices to control the lighting equipment in the home, providing people with safety and comfort. , pleasant high grade family life [3].

The existing lighting control system mainly adopts a photosensitive sensor to measure the outside light, and then automatically controls the lighting. These controls are all set, and it may be inconvenient for the user to need other control. In this paper, a lighting control system was designed using voice recognition technology to realize the intelligent control of lighting. Users can control the lighting through the voice "turn on lights" and "turn off lights" according to their own requirements [4]. Language is commonly used by people and is the most convenient way to communicate. Applying voice recognition technology to lighting control can reduce the complexity of operation and increase the convenience of operation [5].

## **3. Design of Speech Recognition Intelligent Lighting Control System**

The hardware part of the voice recognition intelligent lighting control system mainly includes Arduino controller, sensing system, wireless control system, voice broadcast part and liquid crystal display. The Arduino is a relatively popular electronic interactive product development platform. This platform is composed of hardware and software. Both hardware and software are open source. Anybody can obtain the latest PCB design on the official website of Arduino. In terms of software, Arduino has its own IDE software development environment, adopts C++-like advanced development language, and has a large number of library functions to support, greatly simplifying program development. Given the many advantages of the Arduino development platform, this article is based on the Arduino micro controller, which has many advantages in the innovation of some special function designs [6].

### **3.1 The basic principle of system**

Speech recognition is actually a kind of pattern recognition. The computer first preprocess the front-end signal of the input speech signal. After digitization and noise elimination, feature extraction is performed on the input speech signal to establish a required model library. In the actual identification part, the computer still performs the same preprocessing and feature extraction process on the test speech signal. After extracting the corresponding features, it compares with the voice information in the established voice template library, determines whether there is a match according to the established discriminating system, and identifies the corresponding result for output by matching.

### 3.2 Application of speech recognition system in lighting

The speech recognition of the home lighting system consists of a speech acquisition device and a control center. Unlike smart TVs and air conditioners, home lighting systems need to be wired, but the voice input method is the same. The same can be achieved by remote devices or built-in microphones and other language acquisition devices, but since most of the lighting system is used Built-in microphones are used for voice signal acquisition, and the indoor environment is noisy. This requires a deeper level of noise reduction. And like home air conditioners, home lighting systems are also devices that are not connected to the network. Therefore, the recognition of speech signals must also be performed locally. This can also be achieved through the establishment of a thesaurus, and the establishment of the thesaurus is better than home The air conditioning is much simpler. Finally, the established thesaurus is stored in the memory of the control center, and the intelligence of the home can be realized.

### 3.3 Arduino controller introduction

Arduino is an open source MCU electronic design platform. The hardware part is composed of Oatmeal AVR micro controller, I/O interface and related circuits. The software part includes a standard program compiler and program down loader. It has developed using similar Java and C Language Processing/Wiring. surroundings. Compared to traditional MCUs, Arduino's features include free, open-source ID's, and open-source hardware (including schematics and PCB diagrams). All resources can be downloaded for free, and can be modified on-demand to facilitate sensors and various types. The kind of electronic components connected.

## 4. Intelligent Lighting Control System Design Based on Arduino Speech Recognition

The main controller of this system adopts ArduinoMega2560. ArduinoMega2560 is the core circuit board with USB interface, the core is ATmega2560 single-chip microcomputer, has 54 digital input/output ports (16 channels can be used as PWM output), 16 analog inputs, 4 UART interfaces, a 16MHz crystal oscillator, A USB port, a power outlet, an ICSP header and a reset button. The control board is connected to the computer via a standard USB cable for easy online debugging.

### 4.1 Wireless voice module

The wireless voice adopts YSV0.7 modules, whose core is the LD3320 speech recognition special chip. The module integrates the LD3320 chip with necessary surrounding resistance components on a PCB. The LD3320's chip pins are led through 2×20 pin headers to facilitate the rapid development of the LD3320 chip on the breadboard or a standard DIP40 socket. The module master MCU is a 51-core micro controller STC90LE52. The power supply design uses the LM1117-3.3 chip to provide 3.3V for the LD3320. Connect the pins of the main control MCU to the pins of the LD3320 module, and provide a crystal (4MHz~48MHz) crystal signal to the LD3320 module. Write a program in the main control MCU to recognize the LD3320.

### 4.2 Wireless communication module

At present, Arduino modules that have been used in China include Falcom's A2D series, Wavcome's WMO2 series, Siemens' MC39i series, Ericsson's DM10/DM20 series, and ZXGM18 series. These modules have little difference in function and usage. This wireless communication control part adopts MC39i module, MC39i is lead-free product of new generation dual-band

GSM/GPRS communication module introduced by Siemens. Its simple package is the ideal solution for wireless high-speed data transmission in many application systems, and data can be processed. , voice, SMS and FAX applications, and low power consumption, provide users with always online, high speed, simpler mobile data communication access means, through a unique 40-pin connector (ZIF) to achieve power connection Bidirectional transmission of instructions, data, voice signals and control signals. It is a monitoring system with telephone alarm function. The system uses the network to remotely control the house. When the system detects the wireless voice in the house, the communication module can be used to control the lighting fixture.

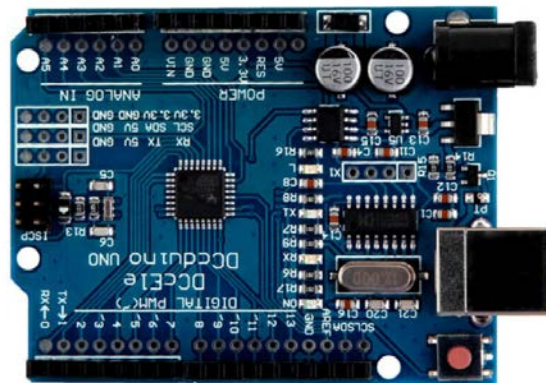

Fig. 1 Arduino controller profile

### 4.3 Wireless control section

Both the system's Arduino coordinator nodes and the terminal nodes use the CC2530 from TI of the United States. This chip is the system-on-a-chip solution for the IEEE 802 protocol. Internally integrates an enhanced 8051 core, 256K programmable memory, 8K RAM, 8- to 14-bit A/D converter, 4 timer/counters, 2 powerful US supporting multiple serial communication protocols, and excellent performance RF transceivers, watchdog timers and more. The hardware supports the CSMA/CA protocol and reduces errors when sending data. At the same time, it also supports accurate digitized Received Signal Strength Indicator (RSSI)/Link Quality Indicator (LQI), enabling programmable output power up to 4.5, so that single chip data transmission without power amplifier Up to 70 to 100m. The chip's MAC is solidified in the transceiver. The MAC layer and the PHY layer are integrated. The 2.4GHz ISM band, which is not required to be applied, is low in cost and low in power consumption, and is powered by a 3.3V power supply.

### 4.4 Design and Implementation of Voice Control Technology

The voice control technology is one of the main control technologies of the system. When the user controls the intelligent lighting system by voice, the system recognizes the user's voice instruction through voice recognition. When the pre-teen instruction with the module matches successfully, the control command is used to message. The queue is sent to the device control thread. This section will focus on the design and implementation of speech recognition modules.

#### 4.4.1 Main program of speech recognition system

The Arduino speech recognition chip can work in trigger recognition mode or cycle recognition mode through software programming. The triggering mode refers to that the Arduino chip starts the identification work after receiving an active trigger signal, such as the user actively triggering through an external button or other means. Although the triggering mode can reduce the interference

of the outside unrelated voice to the recognition process and improve the correctness of the system's voice recognition, each time the voice recognition requires the user to provide an active trigger signal, the operation is cumbersome.

#### 4.4.2 Hardware design of speech recognition system

The Arduino chip is designed and produced by IC Route Corporation and used for speech recognition. Arduino uses a fast and stable optimization algorithm to complete non-specific human speech recognition, that is, no tone limitation. Through software programming, a speech template library can be dynamically established, and 50 candidate identification items are supported, which can meet various scene switching and control of intelligent lighting systems. The request. Moreover, the user does not require prior training and the recognition accuracy is as high as 95%. In addition, the chip also integrates a number of peripheral circuits, including high-precision A / D and D / A channels, audio input and output interfaces. Arduino's efficiency is that it does not require external auxiliary chips such as RAM and Flash to achieve stable and accurate voice recognition.

#### 4.4.3 The description of the internal logic of the chip and some of the pins

- 1) Operating voltage. VDD is 3.3V, the chip pin input voltage range: high level ("1") is 2.3V □ 3.3V, low level ("0") is 0 1V.
- 2) Clock. The chip needs to provide an external clock. The clock frequency range is 448MHz. After the internal PLL, the specified frequency of each module can be generated.
- 3) Reset. When using reset, it must be done with the input voltage stable. The reset signal returns the chip to its initial state and resets each register. After a reset, it enters the sleep state and wakes up the chip through the chip select signal.
- 4) Parallel interface. When using the parallel communication method, it is necessary to use 8 data lines (P0-P7) and 4 control signals (WRB\*, RDB\*, CS\*, A0) and an interrupt return signal INT.
- 5) Serial interface. When using serial communication, only four chip pins are required: chip select (SCS\*), SPI clock (SDCK), SPI input (SDI), and SPI output (SDO). Connect MD to high level and SPIS\* to ground to select SPI communication mode.
- 6) Registers. The address space of the register is 8 bits, the possible value is 00H to FFH. The operation of the chip is achieved by reading and writing registers.

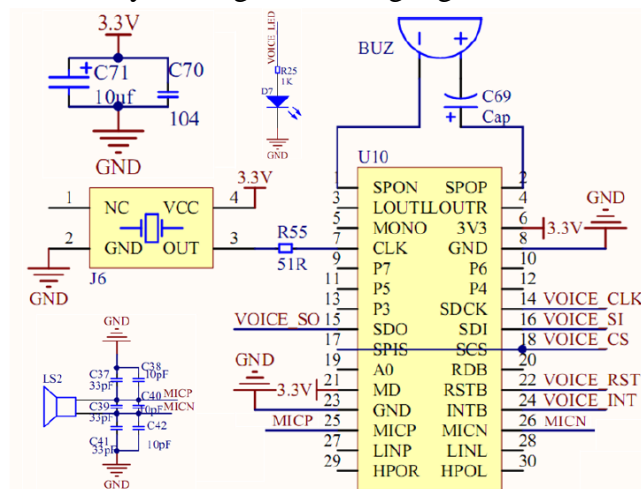

Fig. 2 Speech Recognition System Hardware Schematic



recognition chip can work in trigger recognition mode or cycle recognition mode through software programming. The triggering working mode means that the Arduino system chip starts the identification work after receiving the active trigger signal, such as the user actively triggering through an external button or other means. Although the triggering mode can reduce the interference of the outside unrelated voice to the recognition process and improve the correctness of the system's voice recognition, each time the voice recognition requires the user to provide an active trigger signal, the operation is cumbersome. In order to improve the convenience of the voice control of the intelligent lighting system, the voice recognition system adopts a cyclical operation mode. When there is no matching result after the recognition chip has no voice input command or voice command recognition, the next recognition process is directly started after the recognition process ends; if the voice input instruction and the pre-teen instruction of the module match successfully, the corresponding processing is executed according to the matching result. Then start the next speech recognition process. The realization of the voice control mode of this scheme is accomplished by the voice control thread in the main control software system.

#### **4.6 Design of control node software**

In the control node, the Arduino system is first initialized by the SCM to receive mode, and then waits for the control signal transmitted from the voice recognition module. After the Arduino system receives the wireless signal, it is transmitted to the SCM and the SCM processes the signal, such as the signal. For the switch light instruction from the speech recognition module, the control relay performs a corresponding pull-in or break-out action, otherwise, the current signal is discarded, thereby realizing the realization of the voice control lighting system.

#### **4.7 Verification of identification systems**

In order to improve the convenience of the voice control of the intelligent lighting system, the voice recognition system adopts a cyclical operation mode. When there is no matching result after the recognition chip has no voice input command or voice command recognition, the next recognition process is directly started after the recognition process ends; if the voice input instruction and the pre-teen instruction of the module match successfully, the corresponding processing is performed according to the matching result. Turn on the next speech recognition process. Voice control technology is one of the main control technologies of the intelligent lighting system designed in this paper. You can add or change the voice control password by adding a new identification entry or changing an existing entry in the voice recognition list with corresponding control parameter settings. The voice control password can be flexibly changed and expanded, so that the function control of the intelligent lighting system can be increased or changed, and the controlled and convenience of the system can be improved.

### **5. Conclusion**

An intelligent lighting system based on Arduino micro controller can intelligently turn on, off, and adjust the intensity of light according to the voice recognition system, and change different colors according to the change of ambient temperature. Not only that, the Arduino motherboard with lower cost can be realized, and it is more suitable for entering millions of households, which has great potential value. After being trained in speech recognition intelligent lighting control system, my own comprehensive quality has been greatly improved, and my ability to work and solve problems has

greatly improved. It can simplify the control of lighting equipment in ordinary family life. This system also has certain reference significance for the research of other smart home systems.

## Acknowledgement

This work was supported by the 2017 National College Student Innovation and Entrepreneurship Project (No. 1701029) The 2016 Shenyang Aerospace University (No. 1610615) and the 2018 Shenyang Aerospace University (No. 110418105) (No. 110418106) and (No. 110418107).

## References

- [1] Chen Luzhou, et al. *Arduino programming foundation*. Beijing University of Aeronautics and Astronautics Press. Vol. 23 (2014) No. 6, p. 118-123.
- [2] Rong Xuejuan, Niu Pingjuan, Xu Xiuzhi, Li Xiaoxia, et al. *Intelligent Control System for Indoor Lighting. Instrumentation Users*. Vol. 36 (2009) No. 12, p. 416-419.
- [3] Jiang Weiming, et al. *Current status and development trend of smart home in China*. *Science & Technology Vision*. Vol. 18 (2014) No. 3, p. 326-331.
- [4] Chen Xichun, et al. *Voice control based on LD3320 speech recognition special chip*. *Electronic Technology*. Vol. 26 (2011) No. 5, p. 20-21.
- [5] Hong Jiaping, et al. *Application of LD3320 Embedded Speech Recognition System*. *Microcontrollers & Embedded Systems*. Vol. 31 (2012) No. 9 p. 147-149.
- [6] Cao Yu, Liu Fu, et al. *Design of Home Air Conditioning Control System Based on Speech Recognition*. *Home Appliance Science and Technology*. Vol. 37 (2013) No. 5, p. 262-263.